

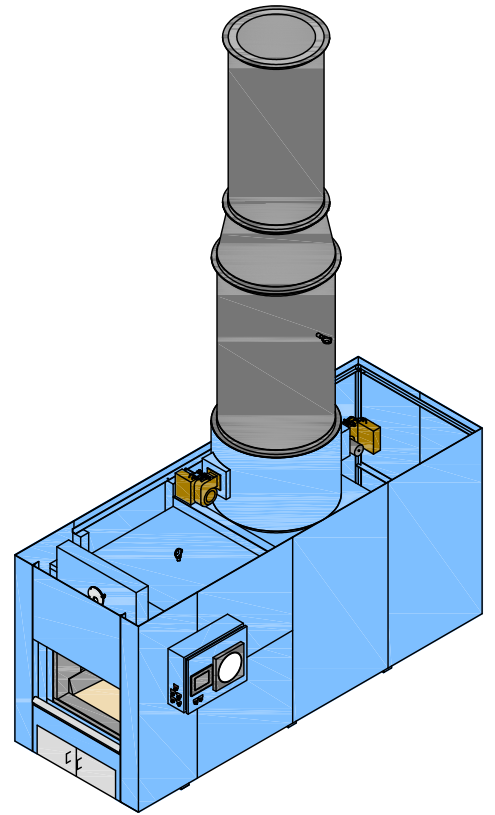

P.O. BOX 1105, TUALATIN, OREGON 97062
 20525 S.W. CIPOLE ROAD, SHERWOOD, OREGON 97140
 (800) 292-9163 or (503) 625-7575 FAX (503) 625-6161
 E-MAIL: tt@thermtec.com

- Latest Design For Efficient Cremation. Not A "Hot Hearth" Design.
- Backed By Over 30 Years Of Combustion Technology.
- Main Burner Positioned For Direct Flame Contact To Case.
- Rapid Heat Up And Cool Down Cycles. Low Noise Operation.
- Tile Floor For Ease Of Replacement. Low Replacement Cost.
- Refractory Lined Stack For Longevity.
- Low Load Height Of 21". Design To Be Used With "Church Truck". No Need For Elevating Table.
- 220 Volts, 40 Amp, 60 Hz, Low 2.3 Horse Power.
- Natural Gas. Operating @ 2 to 5 Lbs. @ 3.8 Million BTU's
- 1.5 Seconds Dwell Time In Final Combustion Chamber



MODEL SQC-300

